

PELLET BURNERS

B-Essential Round 50

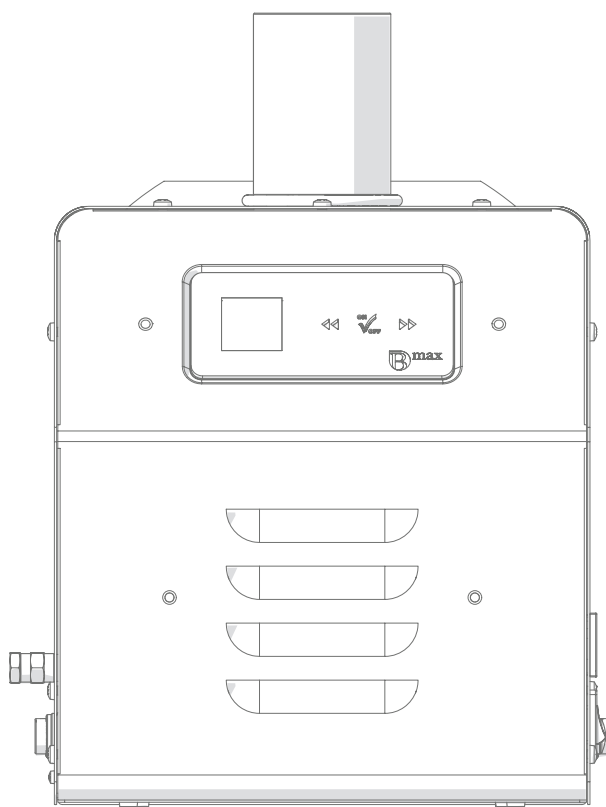

Code EBM0002 - 05/2015 - R0

INSTRUCTIONS FOR USE, INSTALLATION AND MAINTENANCE

EN

Before installing and using the burner, read this manual carefully and keep it close to the burner.

INTRODUCTION

Dear Client,

We would like to thank you for having chosen a **B-Max** appliance.

The **B-Essential Round 50** model chosen by you is a high-performance product with both advanced design and technology, and a high level of reliability and construction quality.

We advise you to entrust the running and maintenance of this appliance to qualified professionals that you know, and also to use only original spare parts when needed.

This manual contains important guidelines and suggestions which should be complied with in order to obtain a simple installation and the best possible use of the appliance.

INDEX

1	General information	3			
1.1	General warnings	3	2.3	Installation location	12
1.2	Restrictions	3	2.4	Mounting the burner	12
1.3	Conformities	3	2.5	Mounting of the loading cochlea and the pellet container	13
1.4	Structure	4	2.6	Release of exhaust fumes	13
1.5	Burner description	5	2.7	Electrical connections	13
1.6	Safety devices	5	3	Start-up	14
1.7	Size	5	3.1	Before starting up the burner	14
1.8	Accessories	5	3.2	First ignition	14
1.8.1	Supply feed cochlea: size and weight	6	3.3	Checks to carry out after the first ignition	14
1.8.2	Pellet container: size and weight	6	3.4	Automatic shut-down and subsequent start-ups	14
1.9	Technical data	6	3.5	Pellet calibration	14
1.10	Operational wiring diagram	7	3.6	Programming of user parameters	15
1.11	Running	8	3.7	List of parameters	17
1.12	Pellet	8	3.7.1	Technical parameters	17
1.13	Control Panel	9	3.8	Alarm messages	18
1.13.1	Viewings on Screen	9	3.9	Problems - Possible causes - Solutions	18
1.14	User parameters	10	4	Maintenance	19
2	Installation	11	4.1	Periodic maintenance	19
2.1	Delivery and identification of the product	11	4.2	Disposal	20
2.1.1	Identification	11			
2.1.2	Contents of the package	11			
2.2	Handling	11			

SYMBOLS USED IN THE MANUAL AND THEIR MEANING



WARNING

To indicate information about particular details.



WARNING CAUTION

To indicate information about particularly sensitive details.



WARNING DANGER

To indicate actions, which, if not carried out correctly, can cause injuries of a generic kind or can cause malfunctions or material damage to the apparatus; so they require special attention and proper preparation.



WARNING DANGER ELECTRICITY

To indicate actions, which, if not carried out correctly, can cause injuries from electricity; so they require special attention and proper preparation.



IT IS FORBIDDEN

To indication actions which **MUST NOT** be taken.

1 GENERAL INFORMATION

1.1 General warnings



WARNING

- This manual is the property of **Elmec Group S.r.l.** and its contents may not be copied or passed on to third parties. All rights reserved.
- The appliance is not designed to be used in environments with a potentially explosive atmosphere.
- This manual is an integral part of the product; make sure that it is always kept with the appliance, even in the case of sale/transfer to another owner, so it can be consulted by the user or by the staff authorised to carry out maintenance and repairs. Read this manual thoroughly before using the appliance in order to ensure operational safety.
- In the event of doubts concerning the conditions and/or working of the appliance or its parts, the local distributor should be contacted for further information.
- Only use original spare parts or ones approved by the manufacturer in order to avoid damage to the product.
- In the event of damage to the packaging of the goods, inform the courier and the product supplier of the problem immediately.
- Carry out the operating tests on the appliance and inform the supplier of the product of any anomalies or running defects found.

1.2 Restrictions



IT IS FORBIDDEN

- Do not use the appliance in areas with a potentially explosive atmosphere.
- Do not carry out modifications to the product without the written authorisation of the manufacturer.
- Do not open the door of the boiler when it is in use.
- Do not store inflammable materials close to the burner, to minimise the risk of fire.
- Do not leave the appliance exposed to the weather.
- Do not install the appliance onto heat generators (boilers, water heaters) situated in places which are poorly ventilated or are very damp. The vents in the building must be sufficiently large to guarantee complete combustion.
- Do not touch the appliance with parts of the body which are wet, or damp and/or with bare feet.
- The appliance must not be used by children or by people who are inexperienced.

1.3 Conformities

The burner **B-Essential Round 50** conforms to European Directives:

- Machinery Directive 2006/42/CE
- Electromagnetic Compatibility Directive 2006/95/CE
- Low Voltage Directive 2004/108/CE

as stated in the Conformity Certificate supplied with the appliance.

1.4 Structure

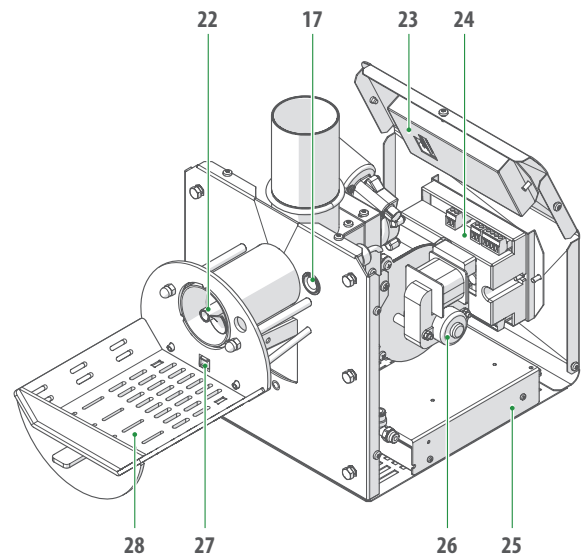
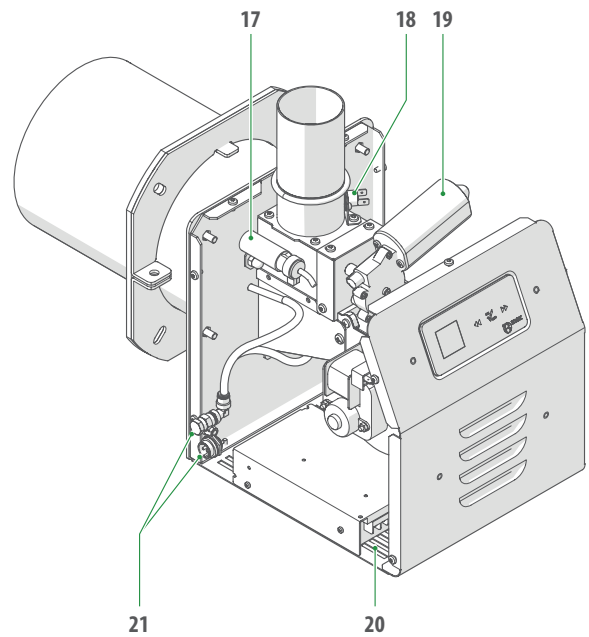
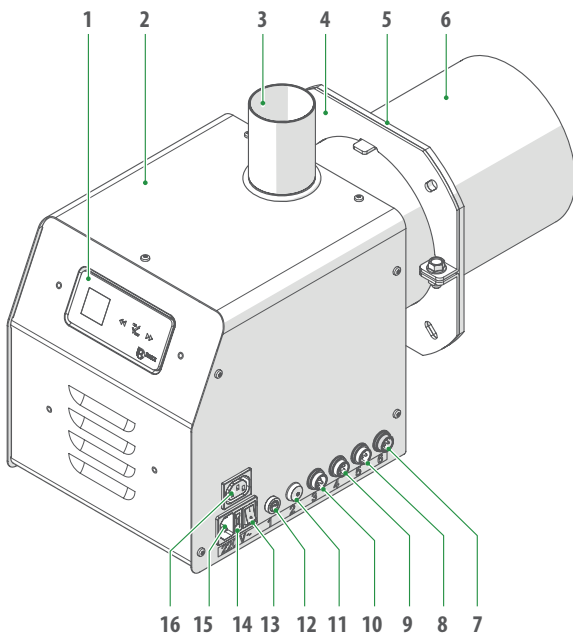

- 1 Control Panel
- 2 Carter housing
- 3 Socket connection hose
- 4 Boiler connection flange
- 5 Washer
- 6 Combustion chamber
- 7 Connection for use with a PC
- 8 External thermostat connection
- 9 Boiler water probe connection
- 10 External cochlea motor connection
- 11 Manual pellet loading button
- 12 Fuse (3.15A delayed)
- 13 Main switch
- 14 Fuse (4A)
- 15 Power socket (230 volts)
- 16 External cochlea fan power socket
- 17 Flame detection photocell
- 18 Burner safety thermostat
- 19 Internal cochlea gear motor
- 20 Combustion air vent
- 21 Compressed air combustion kit (OPTIONAL)
- 22 Internal cochlea
- 23 Display card
- 24 Electronic card
- 25 230V/24V transformer
- 26 Burner fan
- 27 Ignition resistance
- 28 Fuel grill

1.5 Burner description

The burner **B-Essential Round 50** is an extremely versatile appliance and is able to cover a wide range of applications, from installation on new generation boilers, bread ovens or hot air generators to the transformation of old boilers

It is composed of a round combustion head, a main fan with variable speed regulation, a reliable ignition system thanks to the igniter and the flame detection photocell, an internal cochlea for fuel feeding and it is also designed for a compressed air self-cleaning system to be installed.

It must be fitted with a fuel feeding system composed of a cochlea with a flexible connection pipe to the burner, and a pellet container, which is supplied separately as an accessory.

The burner and the whole plant are connected to a control panel with a microprocessor which is fitted onto the appliance and which controls all the other functions, as well as programming the time bands. This is really useful for the Operator, because it allows the appliance to be used only when needed.

1.6 Safety devices

The burner **B-Essential Round 50** is fitted with the following safety devices:

- Burner safety thermostat
- Firebreak valve (optional)

1.7 Size

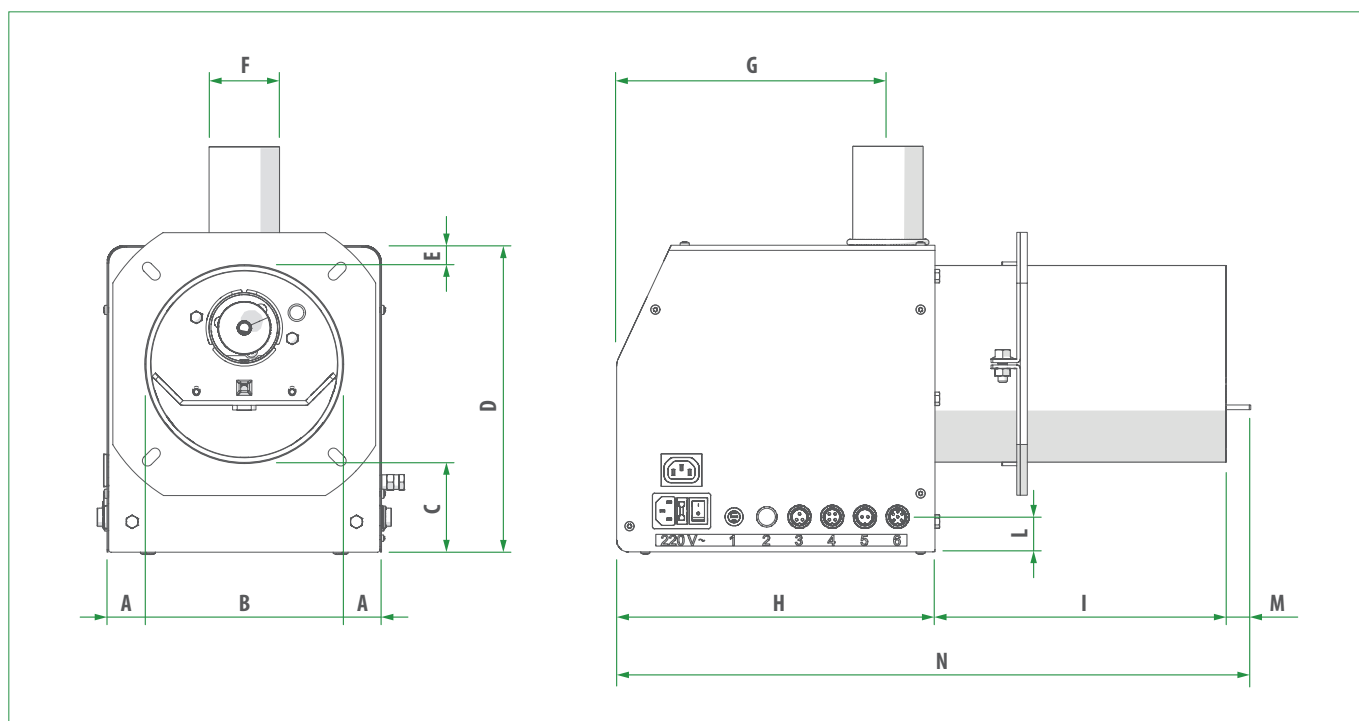

A [mm]	B [Ø mm]	C [mm]	D [mm]	E [mm]	F [Ø mm]	G [mm]	H [mm]	I [mm]	L [mm]	M [mm]	N [mm]
33,5	168,5	77	263	17,5	60	232	272,5	249	30	21	543

1.8 Accessories

The following accessories can be ordered separately from the burner. They should be used to ensure that the burner is properly connected and integrated.

Model	Code
Cochlea (Ø 60 mm)	EBL0003-P01
Pellet container	EBT0001-P01
Pellet container	EBT0002-P00
Compressed air kit	EBK0018-P00

1.8.1 Supply feed cochlea: size and weight

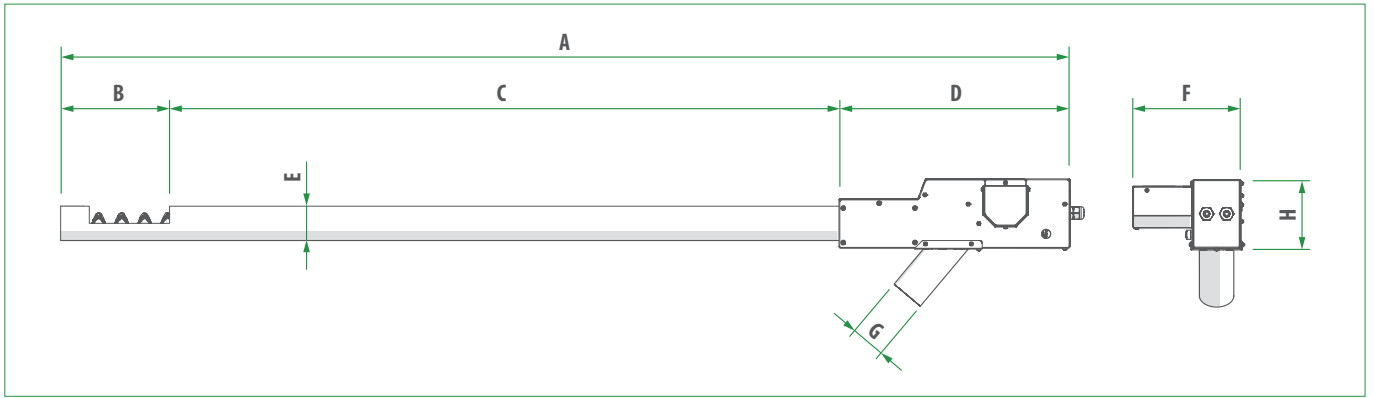

A [mm]	B [mm]	C [mm]	D [mm]	E [Ø mm]	F [mm]	G [Ø mm]	H [mm]	Weight [Kg]
1760	190	1168	402	60	190	60	120	9

1.8.2 Pellet container: size and weight

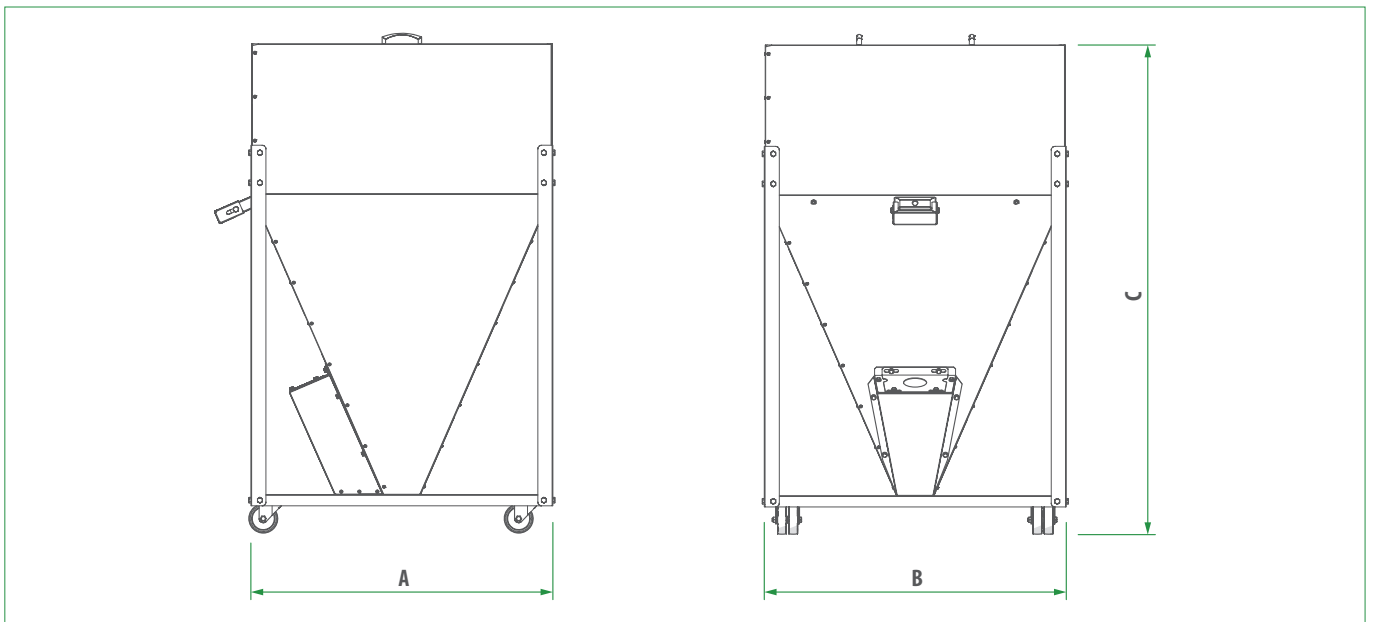

Description	Capacity [Kg]	A [mm]	B [mm]	C [mm]	Weight [Kg]
Pellet container EBT0001-P01	280	750	650	1252	70
Pellet container EBT0002-P00	300	800	800	1300	57

1.9 Technical data

DESCRIPTION	U/M	B-Essential Round 50
Burner power	kW	12 ÷ 55
Power supply	V~Hz	230~50
Average power consumption	W	60
Ignition	W	170
Fuse (delayed)	A	3.15
Noise level	dB(A)	40
Flame height	mm	200
Boiler combustion chamber minimum size	Height	mm
	Width	mm
	Depth	mm
Flue draw	Pa	20

1.10 Operational wiring diagram

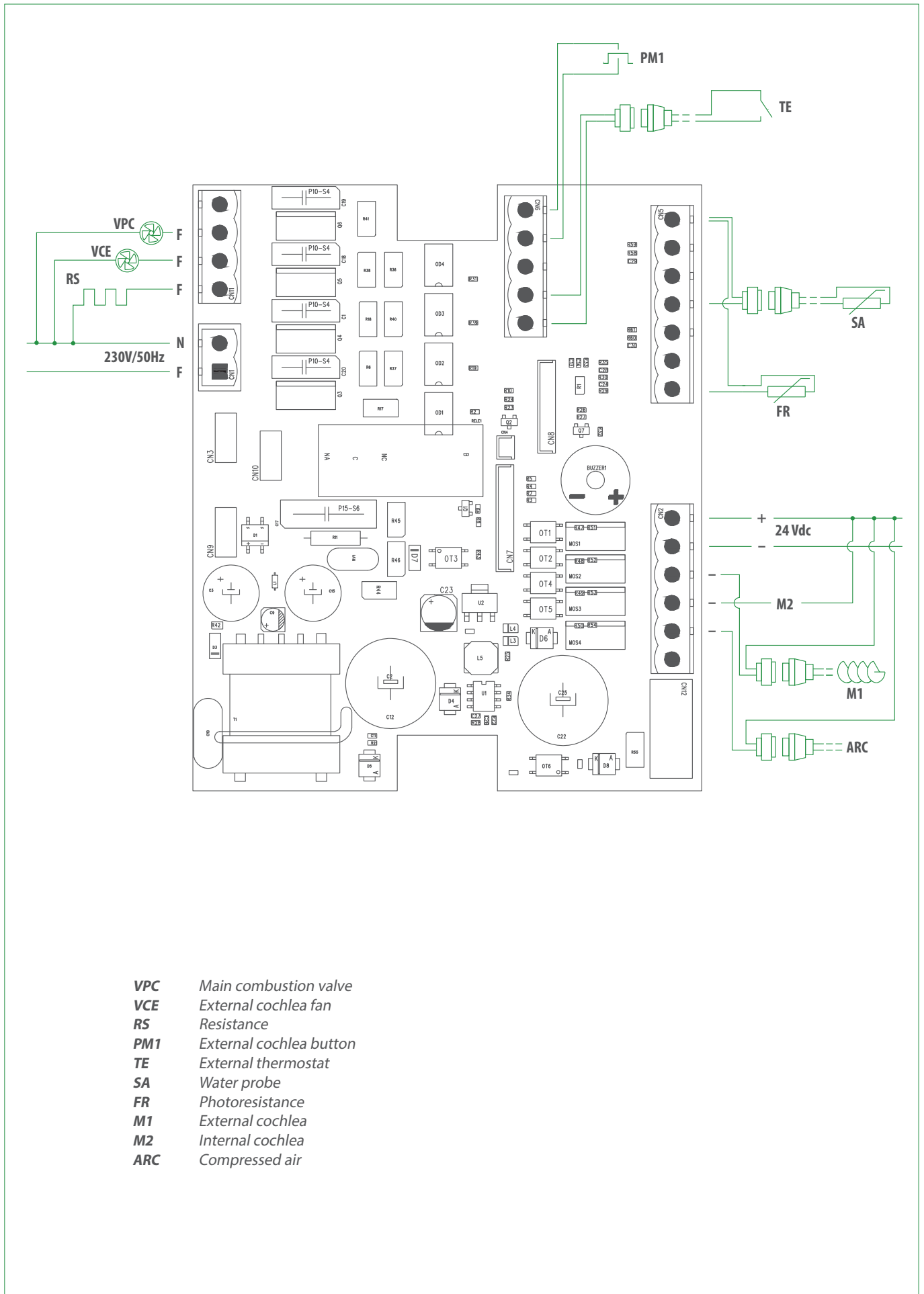

- VPC** Main combustion valve
- VCE** External cochlea fan
- RS** Resistance
- PM1** External cochlea button
- TE** External thermostat
- SA** Water probe
- FR** Photoresistance
- M1** External cochlea
- M2** Internal cochlea
- ARC** Compressed air

1.11 Running

The running of the appliance is controlled from a control panel with a microprocessor which programmes the following phases:

- When a request for heat is sent in start-up mode the main fan, the external cochlea and the internal loading cochlea start up to supply the necessary quantity of pellets for ignition. The internal cochlea starts up 8 seconds later than the external cochlea;
- When the pellet loading for ignition is finished, the ignition resistance is powered electrically, and this ignites the flame the brightness of which is recorded by the photocell within a max. of 20 minutes (safety time). In the event of non-ignition, the burner goes into SHUTDOWN mode. In the event of a SHUTDOWN, in order to reactivate normal running conditions, it is necessary to disconnect the appliance from the mains, remove the cause of the malfunction, and then reconnect it to the power supply;
- After the flame has been correctly detected, the appliance starts to run normally with a gradual increase in power supply until the maximum value programmed is reached, and the appliance continues to operate in modulation until the programmed water temperature for the boiler is reached, or that of a water storage heater if one is installed. While the burner is running, the external and internal cochleas also work according to the programmed ON and OFF times;
- Once the programmed temperature has been reached, the cochleas, both internal and external, are stopped by the control panel, and the pellets remaining in the combustion chamber continue to burn;
- When the brightness of the photocell goes below 20 lux, the fan speed increases to clear the combustion chamber of the last residue and then it stops.

The burner is then ready for the next start-up.



WARNING CAUTION

- The programming of the parameters **MUST** be carried out **EXCLUSIVELY BY QUALIFIED TECHNICIANS AUTHORISED BY Elmec Group S.r.l.**, and only after the Password has been given.
- For the working and shut-down periods of the burner, whether the "time bands" are activated or not should be taken into consideration.
- If the COMPRESSED AIR KIT is also present, cleaning of the combustion chamber takes place at the beginning and at the end of each operational cycle of the burner.



IT IS FORBIDDEN

Programming of the technical parameters from the User Menu.

1.12 Pellet

The appliance is designed and built to burn high-quality pellets which do not contain loose sawdust and that have the following characteristics:

Description	U/M	Pellet
Diameter	mm	6 Din Plus
Length	mm	25 (max)
Density	Kg/m ³	650
Lower heating power	kWh/kg	5
Percentage of humidity	%	Max 8 (of the weight)
Percentage of ash	%	Max 1 (of the weight)

1.13 Control Panel

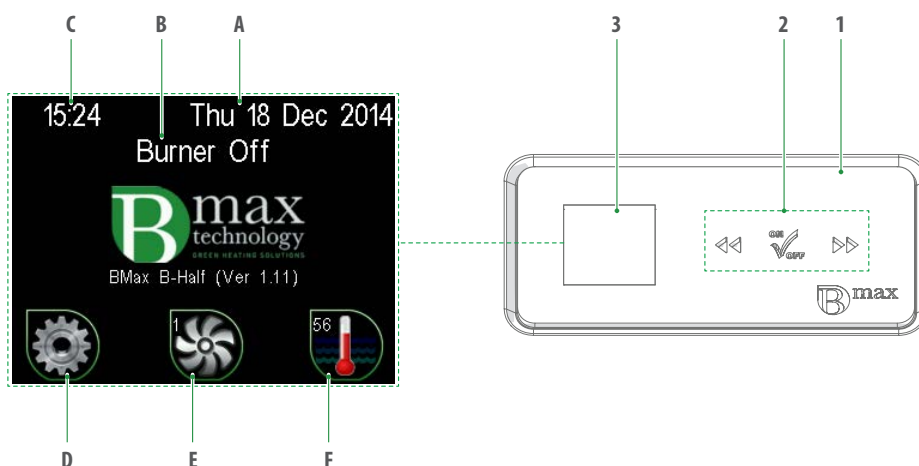

1 CONTROL PANEL

2 OPERATING KEYS



Pressure SHORT (1 second) Access to User Menu

Pressure LONG (> 2 seconds): Check of programmed data

Pressure LONG (> 12 seconds): Reset of all parameters. WARNING!!! With this operation, all previous programming will be erased (*).



Pressure SHORT (1 second) Modification of power

Pressure LONG (> 2 seconds): Ignition/shut-down of burner



Pressure SHORT (1 second) Temperature modification

Pressure LONG (> 2 seconds): Access to Installer's Menu. To gain access it is necessary to know the password (*).

3 SCREEN

- A Date
- B Burner state
- C Time
- D Parameters
- E Power consumed
- F Boiler water temperature

(*) Actions only to be taken by AUTHORISED INSTALLERS.

1.13.1 Viewings on Screen



- Power** Burner power
- Tk1** Loading time of external cochlea (SI)
- Tk2** (NOT USED)
- Lux** Brightness intensity
- Ext** Fan speed of external supply cochlea

1.14 User parameters

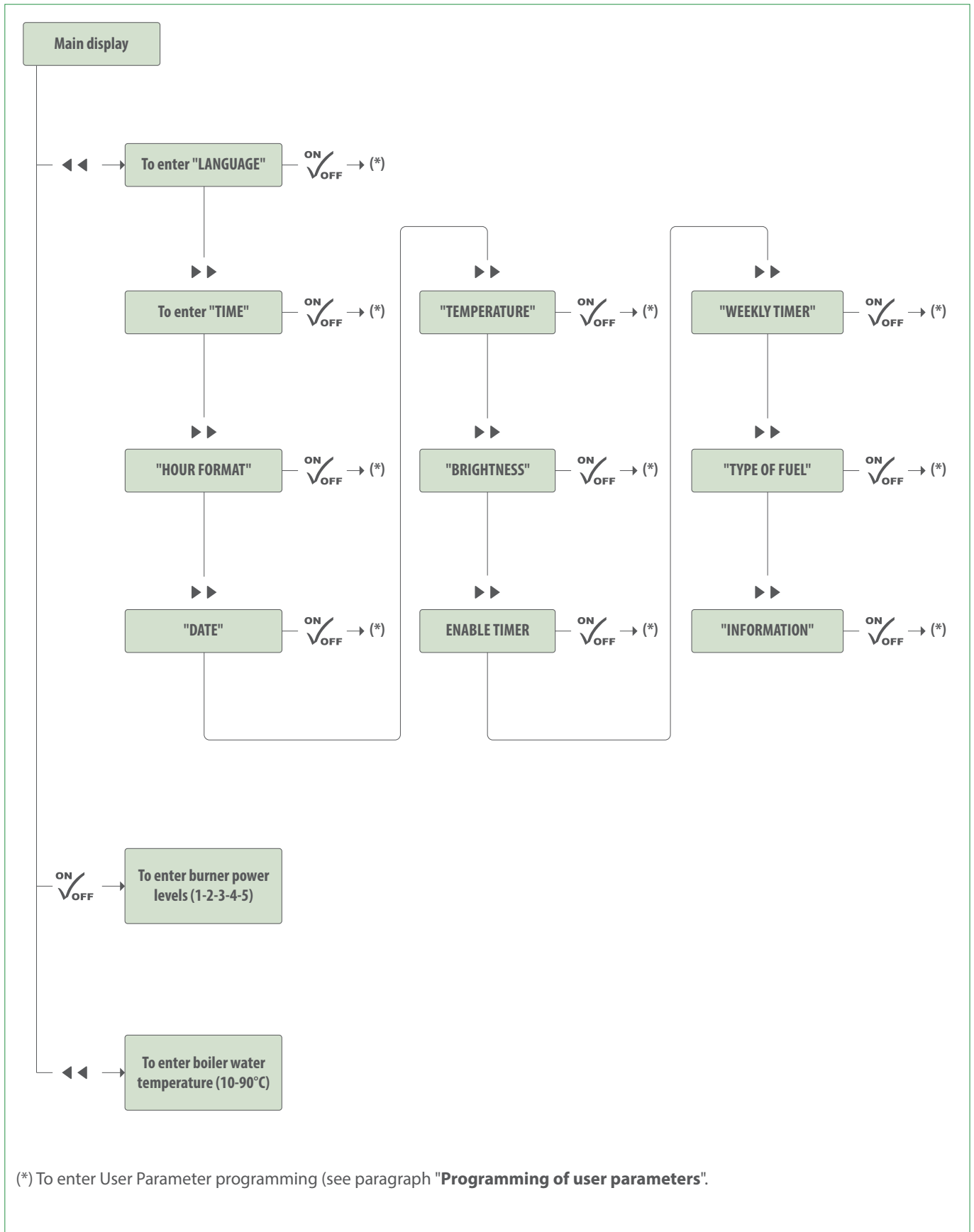

2 INSTALLATION

2.1 Delivery and identification of the product

The appliances **B-Max** are delivered in separate packs and are placed on wooden pallets.

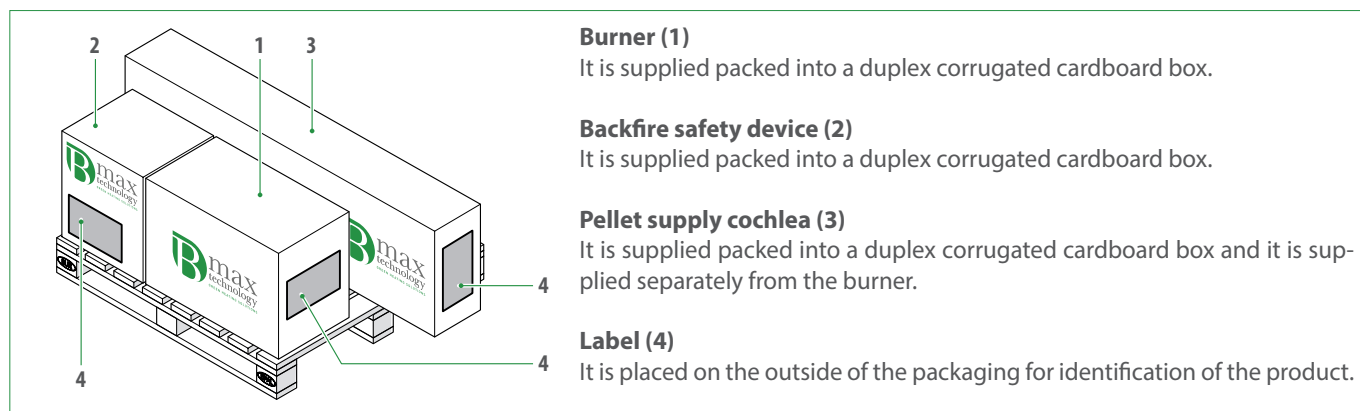

2.1.1 Identification

The identification of each pack is possible by means of the label placed on the outside of every package.



WARNING

On receipt of the product it should be checked that the delivery is complete and in the event of any non conformities or complaints, the organisation that sold the appliance should be contacted.

2.1.2 Contents of the package

Burner

- Burner
- O-ring
- Socket pipe
- Flexible hose
- Seal and burner support flange
- Power supply cable
- Water probe
- Documentation envelope

The following material is supplied in the documentation envelope:

- Instruction manual
- Warranty certificate
- Declaration of conformity
- Catalogue of spare parts
- Bag of bolts and screws
- Connectors for electrical connections

Safety anti-backfire device

- Firebreak valve (optional)

Pellet supply cochlea

- Cochlea complete with:
 - Fan electrical cable
 - 3.15A Delay Fuse.

2.2 Handling

The burner **B-Essential Round 50** was designed to work with heat generators with a depressed combustion chamber; it is necessary therefore for the smoke outlet and the chimney to be designed and realised to satisfy these requirements. The joints must be sealed and resistant to the maximum temperature levels that the fumes can reach.

2.3 Installation location

The pellet burner must be installed in a place that conforms to current Legislation, Regulations and Directives against fire hazards. The appliances and components must be positioned so that there is sufficient space for maintenance and cleaning and for soot removal from the burner, boiler and smoke ducts.

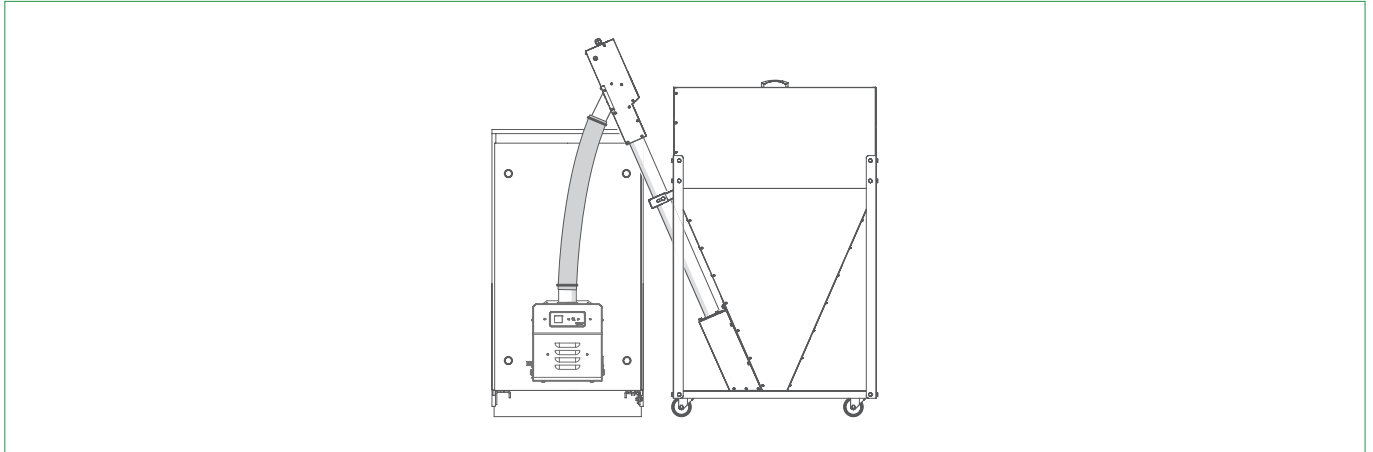

WARNING DANGER

The room must have sufficient ventilation vents which are of the right size and are positioned correctly.

2.4 Mounting the burner

When mounting the burner onto the boiler:

- check that the opening (1) of the door (2) of the boiler is sufficiently large to allow the combustion chamber of the burner to pass through it. If this is not the case, adapt it to the diameter
- make four threaded holes (3) (M8) for fixing the burner support flange
- position the seal (4), supplied with the burner, between the flange (5) and the door (2) of the boiler
- push in the 4 screws (6) (M8) but **ONLY** tighten the two screws which hold the lower split-flange. The two screws of the upper split-flange must **ONLY BE PLACED** but not tightened.
- Insert the combustion chamber of the burner into the boiler as far as is necessary
- tighten the two semi-flanges with the screws (7) and the screws (6), which were previously just placed in position

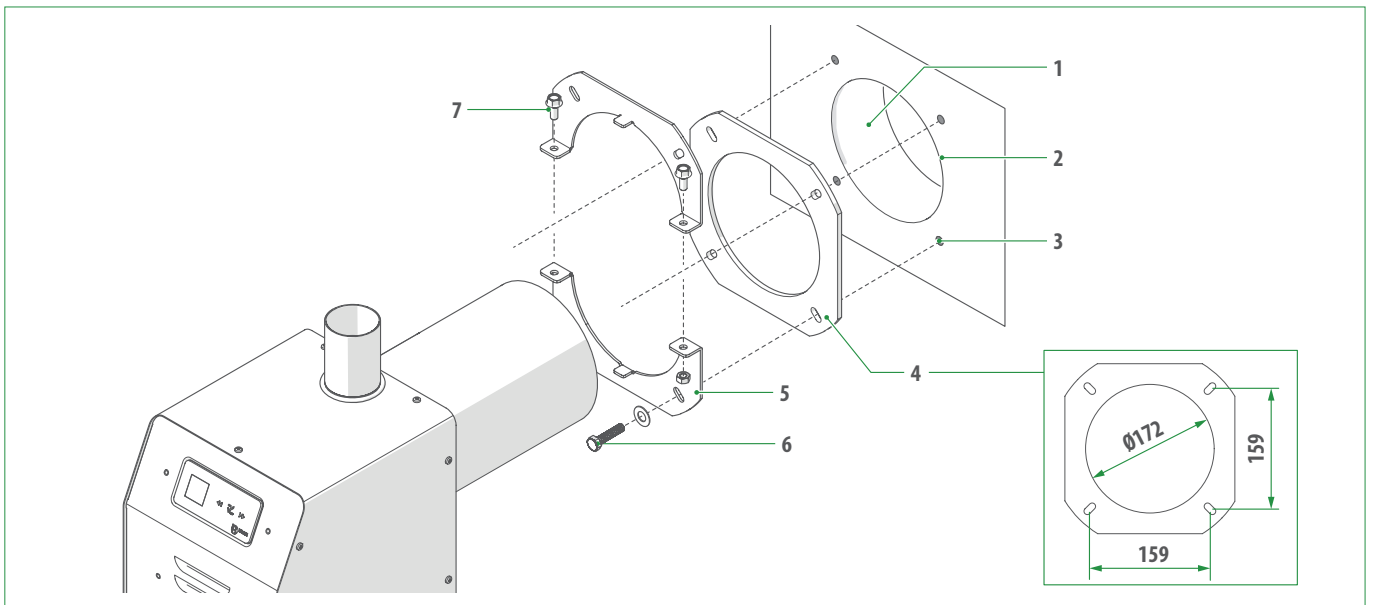

WARNING DANGER

- The burner **MUST** be mounted **ONLY** in the position shown in the diagram. Any other position is **FORBIDDEN**.
- The flame will propagate in a straight line, through the hole of the burner combustion chamber.



WARNING DANGER

The mounting of the burner on the boiler must be sealed to avoid any dangerous smoke escaping. Use the seal supplied by the manufacturer.

2.5 Mounting of the loading cochlea and the pellet container

The mounting of the external loading cochlea and of the pellet container is very important if the burner is to run correctly. It is advisable to buy and use the original accessories, because they have been specifically designed to ensure the correct running of the burner.



WARNING

The manufacturer **Elmec Group S.r.l.** DOES NOT ACCEPT RESPONSIBILITY for any damage to people, animals or things caused by the use of components that are not original.

2.6 Release of exhaust fumes

The burner **B-Essential Round 50** was designed to work with heat generators with a depressed combustion chamber; it is necessary therefore for the smoke outlet and the chimney to be designed and realised to satisfy these requirements. The joints must be sealed and resistant to the maximum temperature levels that the fumes can reach.



WARNING DANGER

- Any applications which are different from the one specified in the manual can cause fire.
- Non-insulated exhaust ducts are a potential source of danger.
- It is possible to install a flue valve which conforms to applicable legislation

2.7 Electrical connections

The burner **B-Essential Round 50** is already wired up in the factory and so professionally qualified personnel must only carry out the actions specified below.

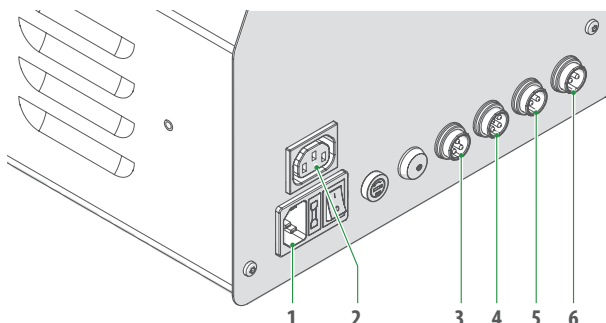

- 1 Power supply socket (230V~50Hz)
- 2 External cochlea fan power socket
- 3 External cochlea motor
- 4 Boiler water temperature probe
- 5 External thermostat connection
- 6 Connection for use with a PC



WARNING DANGER ELECTRICITY

Please remember that **IS OBLIGATORY**:

- to use an omnipolar circuit breaker switch, a disconnect switch in conformity with EN regulations
- to use an L (phase) - N (Neutral) connection
- to connect the earth to an efficient plant grounding device. The manufacturer **Elmec Group S.r.l.** DECLINES ANY RESPONSIBILITY for any damage to people, animals or things, caused by the absence of grounding of the appliance and of the non-compliance with anything specified in this manual.



IT IS FORBIDDEN

Use the water pipes for the grounding of the appliance.

3 START-UP

3.1 Before starting up the burner

Before starting up the appliance check that:

- the burner is correctly mounted on the boiler door and that this latter is firmly closed
- the cochlea and the burner flexible connection hose are positioned correctly
- the pellet container has been filled
- the water temperature probe has been correctly positioned
- the boiler and the plant has been filled with water
- the hydraulic circuit valves are open
- the fumes exhaust duct has been set up properly.

3.2 First ignition

Connect the burner power supply, positioning the plant main switch and the main burner switch in the "ON" position, and check that the screen lights up.

The burner has already been calibrated for maximum power in the factory, so for the first ignition just press the \checkmark_{OFF} key for about 2 seconds and wait for the flame to light.

Leave the burner in the continuous running mode, at maximum power for about 15 minutes, and then with a flue gas analyser check that the values recorded are close to the ones indicated in the table:

Description	U/M	Correct value
O ₂	%	~ 10
CO (average)	mg/cm ³	< 500
Exhaust temperature	°C	120 ÷ 200

Press the \checkmark_{OFF} key to turn off the burner and leave it to cool.



WARNING

This operation must be carried out ONLY by authorised and qualified technicians.

3.3 Checks to carry out after the first ignition

After the first ignition, with a cold burner:

- disconnect the pellet supply tube from the burner
- open the boiler door and check that on the combustion chamber grill THERE IS NO unburnt material. If this is not the case, it is necessary to modify the settings on the basis of the specific needs (the combustion air and the quantity of fuel) and to repeat the "FIRST IGNITION" phase previously described.

3.4 Automatic shut-down and subsequent start-ups

Once the heat demand has been satisfied the supply of pellets is stopped, and the burner adapts its speed in order to burn the residual pellets present in the combustion chamber, until the minimum brightness level (20 Lux) appears, which is recorded by the photocell. When 20 lux is reached, the fan speeds up to maximum velocity (for ...?!) in order to clean the combustion chamber of any residue and then stops.

At every request for heat all the phases described previously are repeated.

3.5 Pellet calibration

The calibration of the quantity of pellets necessary for ignition and for running the burner is achieved as follows:

- fill the pellet container
- pull out the flexible hose from the burner socket and place it in a recipient (basin)
- Check that there are no requests for heat
- Connect the burner power supply, positioning the plant main switch and the main burner switch in the "ON" position, and check that the screen lights up
- press the button (manual loading) until the pellets are falling continuously into the recipient (the cochlea is full of pellets)
- empty the recipient and press the button again (manual loading) for about 6 seconds (loading time for max power 5), controlling the time with a stopwatch, and weigh the pellets which have fallen into the basin.

Calculate the maximum burner power using the following formula:

$$Y * 5 / 45 * 3,6 = z \text{ (kW/h)}$$

where

- Y** Quantity of pellets (in grams) weighed in 6 seconds (loading time for max power)
- 5** p.c.i. of the pellets
- 45** max. cochlea time
- 3,6** pellets in Kg/h.



WARNING CAUTION

If the type of pellets being used is changed (not advisable) the calibration of the pellets **MUST** be repeated, because the combustion characteristics will change.

3.6 Programming of user parameters

The programming of the user parameters can be done following the flow diagram above, after connecting the burner to the mains.

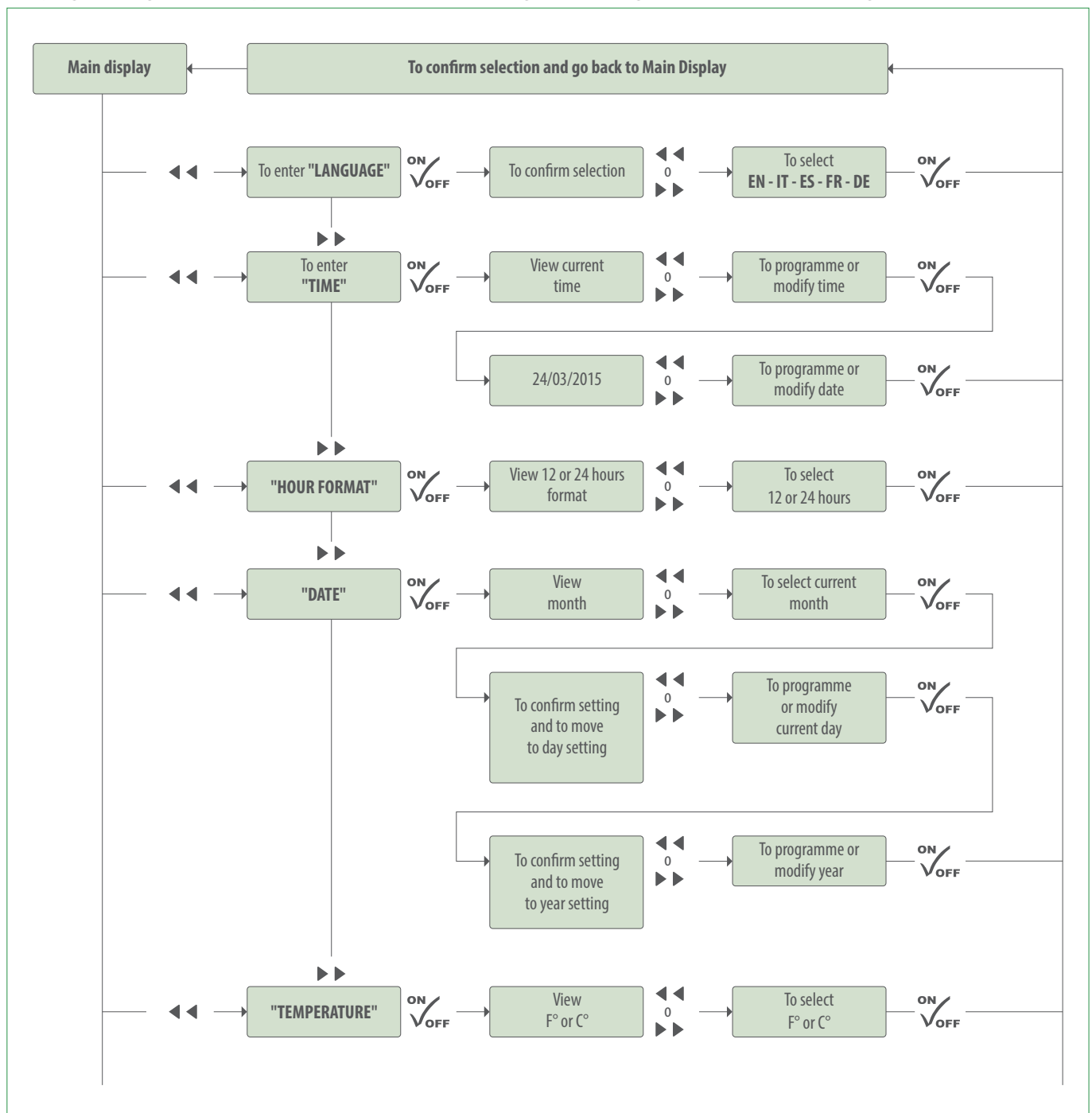

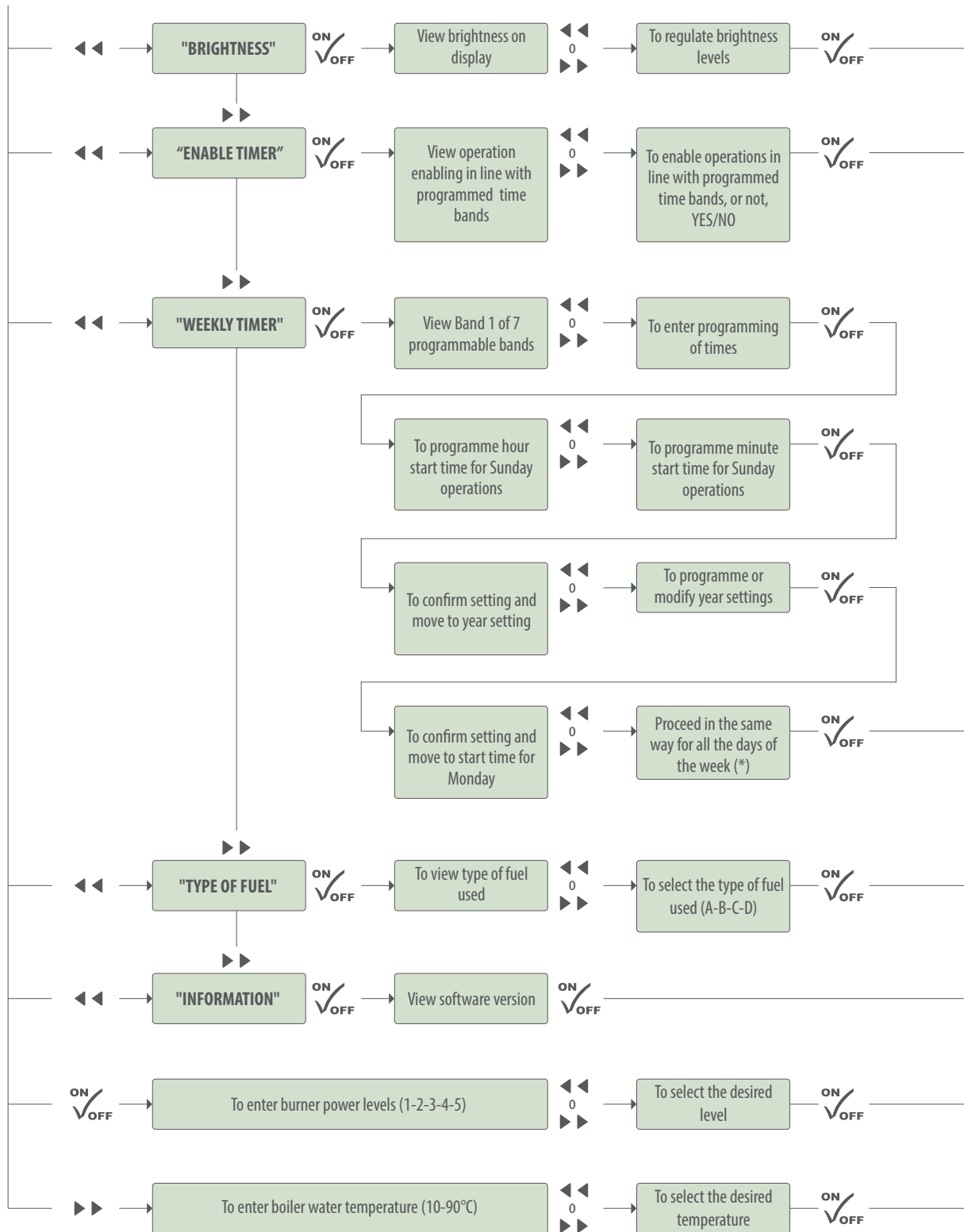

(*)

- 1 When the Saturday times have been programmed, press the key \checkmark/OFF to save the programmed times and to prepare for programming the Band 2 times
- 2 Press the key \gg to select Band 2. Press the Key to confirm \checkmark/OFF and enter the level for programming the start and end of running times
- 3 To programme the times, proceed as described above
- 4 Repeat the same procedure to programme the times of all the available time bands (up to 7)

To prevent the burner working in a particular time band, programme both the start time and the end time at 00.00.

3.7 List of parameters

3.7.1 Technical parameters

Viewing of screen	Description	U/M	Field	Factory default setting
TECHNICAL				
Δ temp. -	Hysteresis for water regulation temperature. When the set temperature is reached, the burner shuts off. If the temperature of the hysteresis value programmed falls below the set value, the burner starts up again.	°C	2 ÷ 30	2
Δ temp. +	Maximum value the water temperature can reach beyond the set value. If the temperature exceeds the set value of the amount selected (5°C) the burner shuts off and only starts up again when the temperature programmed in the temperature control parameter is reached "Δ temperature ceck".	°C	1 ÷ 5	5
Enabling of 2nd pellet container	Enables the use of 2nd pellet container.		On / Off	Off
External thermostat	Enables the use of an external thermostat (e.g. TA or TB).		On / Off	Off
Viewing on display h2o	Enables viewing on the screen of the temperature programmed for the water in the boiler.		On / Off	On
110V / 60Hz	To be activated in the countries with this mains voltage.		YES / NO	NO
IGNITION				
Pellet pre-loading (s)	This parameter sets the first pellet loading time.	sec	0.0 ÷ 60.0	10
Compressed air (s)	Duration of cleaning process with compressed air.	sec	0.0 ÷ 20.0	6,00
Initial ventilation	Fan intensity in the ignition phase after the "pellet pre-loading" phase ("precarico pellet").	rpm	0 ÷ 300	160
Minimum lux start-up	Minimum brightness to establish a regular ignition.	Lux	0 ÷ 1000	60
Lux shut-down	If the brightness goes below the level recorded during the time regulated within the Dead Band parameter ("Banda Morta"), the burner shuts down. If this happens during normal running of the appliance, the signal ERROR appears on the display.	Lux	0 ÷ 100	20
Dead band (s)	This is the time during which the optical sensor must continuously record a value higher than the parameter "Minimum lux start- up" ("Lux minimo avvio"). Every time the values recorded go below the parameter Minimum lux start- up ("Lux minimo avvio"), the count starts up again.	sec	0 ÷ 600	60
Flame stabilisation (m)	Time deemed necessary for stabilisation of the flame, after which the burner is enabled to start up.	min	0 ÷ 20	1
POWER LEVELS				
Type	Type of combustion being used.		A-B-C-D	A
Fuel supply interval.	Time between one pellet reloading and the next.	Sec.	1.0 ÷ 90.0	45.0
Start-up	Filling Time from external cochlea to start.	Sec	0.0 ÷ 30.0	3,0
Fan	Fan speed at start.	rpm	0 ÷ 300	220
Power 1	Filling Time from external cochlea to Power 1.	Sec	0.0 ÷ 60.0	2,0
Fan	Fan speed at Power 1.	rpm	0 ÷ 300	150
Power 2	Filling Time from external cochlea to Power 2.	Sec	0.0 ÷ 60.0	3,5
Fan	Fan speed at Power 2.	rpm	0 ÷ 300	160
Power 3	Filling Time from external cochlea to Power 3.	Sec	0.0 ÷ 60.0	4,5
Fan	Fan speed at Power 3.	rpm	0 ÷ 300	170
Power 4	Filling Time from external cochlea to Power 4.	Sec	0.0 ÷ 60.0	5,5
Fan	Fan speed at Power 4.	rpm	0 ÷ 300	180
Power 5	Filling Time from external cochlea to Power 5.	Sec	0.0 ÷ 60.0	6,5
Fan	Fan speed at Power 5.	rpm	0 ÷ 300	200
NOTA				
The fill-up time depends on the power level programmed and on the type of fuel being used				
The fan speed depends on the fuel (type and quantity) and on the flue draw				
CLEANING				
Cleaning intervals (m)	The interval between the cleaning of the combustion grill carried out by the burner fan and the cleaning carried out with compressed air.	min	0 ÷ 300	60
Grill cleaning (s)	Duration of cleaning process with burner fan running at maximum power.	sec	1 ÷ 180	30
Fan cleaning	Fan speed during cleaning phase.	rpm	0 ÷ 300	300
Compressed air	Presence of compressed air kit (optional).		YES / NO	NO
External fan	Speed of cochlea fan.	rpm	0 ÷ 300	300
Shutting down				
Duration	The time during which the ventilator goes on running at max. power when the burner has been shut down due to an alarm going off. The objective is to burn all the residual fuel left on the grill. This cycle is activated when the burner is off.	min	0 ÷ 20	2
Ventilation	Fan speed during shut-down phase.	rpm	0 ÷ 300	300
External thermostat.	This determines the operational mode of the burner once the environment set value programmed has been reached.	min	0 ÷ 90	0

Viewing of screen	Description	U/M	Field	Factory default setting
PAGE - TEST				
Resistance Start-up / Shut-down	Ignition resistance.		ON/OFF	OFF
Air Start-up / Shut-down	Activates 24V electrovalve power supply for the compressed air kit.		ON/OFF	OFF
Alarm Start-up / Shut-down	Activates the 230V output.		ON/OFF	OFF
Cochlea Shut-down	Internal cochlea.		ON/OFF	OFF
Tank shut-down	External cochlea.		ON/OFF	OFF
Internal Fan	Burner fan.	rpm	0 ÷ 300	
External Fan.	Cochlea fan.	rpm	0 ÷ 300	
NOTA This checks that the main components of the burner are working correctly.				
REMOTE CONTROL				
Module	Must be activated to connect the GSM module to connector 6 on the burner.		YES / NO	NO

3.8 Alarm messages

In the event of a fault or malfunction, the following signs appear on the screen:

Description
Failed ignition
Blackout alarm
Faulty water probe alarm
Fuel finished alarm
TS overheating
Fuel finished

3.9 Problems - Possible causes - Solutions

In the table below are reported the most common problems with their possible solutions.

Problem	Possible cause	Solution
Failed ignition	Empty pellet container	Fill the container
	Disconnected or broken external cochlea cable	Reconnect the cable or find the break
	Ignition resistance broken	Check the resistance and/or substitute it
	Combustion grill is blocked	Pull out the grill and clean it
	Internal cochlea blocked	Check the internal cochlea and remove any blockages
Power supply absent	Electrical supply to burner not present	Check the mains supply
		Check that the electrical cables are connected correctly Check that the general switches and the switches on the burner are in the correct position
Water probe	The probe is incorrectly positioned or connected	Check its position and connections
	Probe faulty	Replace the probe
Fuel finished	Pellet container empty	Fill the container
	Disconnected or broken cochlea cable	Re-establish the connection
	Cochlea motor not working	Check the motor

4 MAINTENANCE

4.1 Periodic maintenance

Periodic maintenance, as well as being necessary for the optimal functioning of the burner and the plant, is required by Law and if maintenance regulations are not observed, there can be problems or even fines.

Maintenance must be entrusted to and carried out SOLELY by qualified technicians.

The pellet burner **B-Essential Round 50** was designed to require minimal maintenance, the frequency of which depends directly on the quality and size of the pellets used (certified or not) and on adjustments made to the settings.



WARNING DANGER ELECTRICITY

Before carrying out any maintenance activity, disconnect the appliance from the mains, and put the general switches on the plant into the OFF position, but also the main ones on the burner and the boiler (if present).



WARNING CAUTION

- When carrying out maintenance, all the Personal Safety Equipment required by current Legislation must be used.
- Periodic maintenance refers to the whole plant in which the burner is installed.
- If non-certified pellets are used, the indications below are rendered null and void, since the characteristics of the fuel are not known.
- In the event of the use of non-certified pellets, **Elmec Group S.r.l.** DOES NOT ACCEPT RESPONSIBILITY for any breakages or malfunctions or for any possible harm to people, animals or things, or to the environment.
- The table is only for suggestion purposes and is not binding.
- For cleaning the housing of the burner, use a damp cloth with water and soap or water and methylated spirits, or with specific non-abrasive products.

Description	Periodic			
	When necessary	Weekly	Six-monthly	Annual
BURNER CLEANING				
Combustion chamber - ash and slag		x		x
Burner fan			x	x
Internal cochlea Photocell			x	x
Ignition resistance				
Pellet container	Filling	x		x
Combustion air suction grill		x		x
External cochlea bearings Possible greasing or lubrication				x
External cochlea fan				x
Control of perishable parts			x	x
Control of cables and electrical connections			x	x
PLANT CLEANING				
Smoke channel and flue pipe			x	x
Inside and back part of the boiler			x	x
Control of perishable parts			x	x
Control of exhaust fumes			x	x



WARNING CAUTION

- After any maintenance work, checks should be made to ensure that the burner is operating correctly.
- Use of the appliance in a poor state of maintenance could cause unexpected and potentially extremely dangerous malfunctions.
- If any parts have to be substituted, only original parts should be used.



WARNING

The manufacturer **Elmec Group S.r.l.** DOES NOT ACCEPT RESPONSIBILITY for any damage to people, animals or things caused by the use of components that are not original.

4.2 Disposal

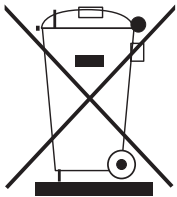

At the end of its working life the burner **B-Essential Round 50** must be disposed of correctly using selective sorting, in line with current legislation; for example European Directives 2002/95/CE RoHS and 2002/96/CE RAEE.



ELMEC GROUP S.R.L.

Loc. Ca' d'Oro • 36020 • Asigliano Veneto (VI)

ITALY

Tel + 39 0444 772023

Fax +39 0444 773129

Mail info@b-max.com

Web www.b-max.com